

Actuator

An actuator is the electromechanical mechanism that transfers the RF contacts from one position to another upon DC command.

Arc Suppression Diode

A diode is connected in parallel with the coil. This diode limits the “reverse EMF spike” generated when the coil de-energizes to 0.7 volts. The diode cathode is connected to the positive side of the coil and the anode is connected to the negative side.

Date Code

All switches are marked with either a unique serial number or a date code. Date codes are in accordance with MIL-STD-1285 Paragraph 5.2.5 and consist of four digits. The first two digits define the year and the last two digits define the week of the year (YYWW). Thus, 0532 identifies switches that passed through final inspection during the 32nd week of 2005.

Failsafe

A failsafe switch reverts to the default or failsafe position when the actuating voltage is removed. This is realized by a return spring within the drive mechanism. This type of switch requires the continuous application of operating voltage to select and hold any position. (Multi-position switches are normally open with no voltage applied).

Latching

A latching switch remains in the selected position whether or not voltage is maintained. This can be accomplished with either a magnetic or mechanical latching mechanism.

Indicator

Indicators tell the system which position the switch is in. Other names for indicators are telemetry contacts or tellback circuit. Indicators are usually a set of internally mounted DC contacts linked to the actuator. They can be wired to digital input lines, status lights, or interlocks. Unless otherwise specified, the maximum indicator contact rating is 30 Vdc, 50 mA, or 1.5 Watts into a resistive load.

Internal Termination

Unselected ports are connected internally to a matched load. The load is a 50-Ohm resistive device. The max RF power rating is 2 watts CW. Without the internal termination option, the unselected ports are open circuits.

Isolation

Isolation is the measure of the power level at the output connector of an unconnected RF channel as referenced to the power at the input connector. It is specified in dB below the input power level.

Multi-Throw Switch

A multi-throw switch is a switch with one input and three or more output ports. The CCT-58 can switch a microwave signal to any of 2, 3, 4, 5 or 6 outputs from a single common input.

Multi-Throw Latching Switch

DUAL PULSE SWITCHING COMMAND CHARACTERISTICS:

1. APPLIES FOR SINGLE-POLE MULTI-THROW LATCHING SWITCH ONLY.
2. MUST APPLY RESET PULSE FIRST (BREAK-BEFORE-MAKE).
3. RESET AND SET DEFINITIONS
 RESET: OPEN ALL RF PATHS (POSITIONS).
 SET: CLOSE THE SELECTED RF PATH (POSITION).
4. COMMAND PULSE TIMING:

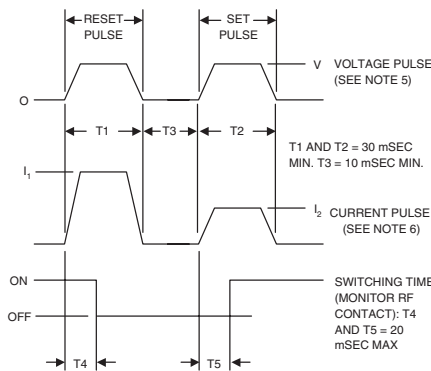

5. COMMAND SWITCHING VOLTAGE:
 V = 26-32 VDC PULSE

6. SWITCHING CURRENT:

SWITCHING CURRENT AT 28 VDC AND 20°C		
NO. OF POS.	RESET (I ₁)	SET (I ₂)
3 POS.	270 mA	90 mA
4 POS.	360 mA	90 mA
5 POS.	450 mA	90 mA
6 POS.	540 mA	90 mA

Self-Cutoff

The self-cutoff option disables the actuator current on completion of actuation. Either a series contact (linked to the actuator) or an IC driver circuit provides the current cutoff. This option results in minimum power consumption by the RF switch. Cutthroat is another name used in the industry for this option. Pulse latching is a term sometimes used to describe a switch without this feature.

SPDT Switch

A single-pole double-throw switch has one input and two output ports.

Switching Time

Switching time is the total interval beginning with the arrival of the leading edge of the command pulse at the switch DC input and ending with the completion of the switch transfer, including contact bounce. It consists of three parts: (1) inductive delay in the coil, (2) transfer time of the physical movement of the contacts, and (3) the bounce time of the RF contacts.

Transfer Switch

A four-port switch consisting of two independent pairs of RF paths. These pairs are actuated simultaneously. This actuation is similar to that of a double-pole double-throw switch. See application notes for typical usage.

Glossary

TTL Switch Driver Option

As a special option, switch drivers can be provided for both failsafe and latching switches, which are compatible with industry-standard low-power Schottky TTL circuits.

T-Option

This option is for TTL Driver. There is one control input for each position. See the logic table.

TD-Option

This option includes a decoder. The 3-bit parallel command is decoded to internally select the appropriate position. See the logic table.

The TD-Option increases the Vsw supply current demand by 50mA max at 28 Vdc and +20°C.

Failsafe uses 1 circuit. Latching uses 2 circuits (Vsw & C are common to both circuits).

SPDT Failsafe		
Logic Input		RF Path
1		IN to 1 IN to 2
		Normally Closed Normally Open
0		On Off
1		Off On

SPDT Latching			
Logic Input		RF Path	
1	2	IN to 1	IN to 2
0	0	No change	
1	0	On	Off
0	1	Off	On
1	1	Forbidden	

Transfer Failsafe CCS-37S10-T or CCS-47N10-T					
Logic Input		RF Path			
1		1-2	3-4	1-3	2-4
0		On	On	Off	Off
1		Off	Off	On	On

Transfer Latching CCS-37S60-T or CCS-47N60-T					
Logic Input		RF Path			
1	2	1-2	3-4	1-3	2-4
0	0	No Change			
1	0	Off	Off	On	On
0	1	On	On	Off	Off
1	1	Forbidden			

Multi-Throw, Normally Open CCR-38S160-T (T-Option)											
Logic Input						RF Position					
1	2	3	4	5	6	J1	J2	J3	J4	J5	J6
1	0	0	0	0	0	On	Off	Off	Off	Off	Off
0	1	0	0	0	0	Off	On	Off	Off	Off	Off
0	0	1	0	0	0	Off	Off	On	Off	Off	Off
0	0	0	1	0	0	Off	Off	Off	On	Off	Off
0	0	0	0	1	0	Off	Off	Off	Off	On	Off
0	0	0	0	0	1	Off	Off	Off	Off	Off	On

Multi-Throw, Normally Open CCR-38S160-TD (TD-Option)									
Logic Input			RF Position						
1	2	3	J1	J2	J3	J4	J5	J6	
0	0	0	Off	Off	Off	Off	Off	Off	Off
1	0	0	On	Off	Off	Off	Off	Off	Off
0	1	0	Off	On	Off	Off	Off	Off	Off
1	1	0	Off	Off	On	Off	Off	Off	Off
0	0	1	Off	Off	Off	On	Off	Off	Off
1	0	1	Off	Off	Off	Off	On	Off	Off
0	1	1	Off	Off	Off	Off	Off	Off	On

Multi-Throw, Latching CCR-39S160-T (T-Option)												
Logic Input							RF Position					
1	2	3	4	5	6	R	J1	J2	J3	J4	J5	J6
1	0	0	0	0	0	0	On	Off	Off	Off	Off	Off
0	1	0	0	0	0	0	Off	On	Off	Off	Off	Off
0	0	1	0	0	0	0	Off	Off	On	Off	Off	Off
0	0	0	1	0	0	0	Off	Off	Off	On	Off	Off
0	0	0	0	1	0	0	Off	Off	Off	Off	On	Off
0	0	0	0	0	1	0	Off	Off	Off	Off	Off	On
0	0	0	0	0	0	1	Off	Off	Off	Off	Off	Off

Multi-Throw, Latching CCR-39S160-TD (TD-Option)											
Logic Input			RF Position								
1	2	3	J1	J2	J3	J4	J5	J6			
0	0	0	— Coil Off —								
1	0	0	On	Off	Off	Off	Off	Off	Off	Off	Off
0	1	0	Off	On	Off	Off	Off	Off	Off	Off	Off
1	1	0	Off	Off	On	Off	Off	Off	Off	Off	Off
0	0	1	Off	Off	Off	On	Off	Off	Off	Off	Off
1	0	1	Off	Off	Off	Off	On	Off	Off	Off	Off
0	1	1	Off	Off	Off	Off	Off	Off	Off	Off	On
1	1	1	— Reset —								